



VALVES, FITTINGS & TUBING PRESSURE VESSELS & REACTORS



High Pressure Equipment
A GRACO Company



HiP... Our Name is High Pressure

High pressure valves, fittings and tubing manufactured to the highest quality standards, delivered with the shortest lead times, and priced to make you money... it's been the focus at HiP throughout our more than 65 year history. We offer a broad product portfolio capable of handling pressures up to 150,000 psi and carry an extensive inventory allowing us to offer same day shipping of many items. In addition to our high pressure valves, we offer a complete line of reactors and pressure vessels and an expanded family of pumping systems and instrument valves.

In addition to our standard products, we offer a complete line of valves and fittings for oil and gas industry use with sour gas (H₂S). For applications involving specialty gases, corrosive liquids, and extreme temperatures/conditions, we'll make our products using exotic alloys and temperature extensions, as well as design and build a solution to meet your exact requirements, such as our popular custom manifolds. This dedication to satisfying our loyal customers is the driving force behind our continued growth, including our passing the 4 million high pressure valves and fittings shipped milestone.

Committment to Quality

As a company that exclusively deals in elevated pressure applications, we understand that our customers depend on our products to provide safe and reliable operation at pressures as high as 150,000 psi. Throughout our history we have been dedicated to continuous improvement in all aspects of our manufacturing operation and customer service. This commitment has only increased over time, including our joining the Graco family of companies and implementing their world class quality systems.

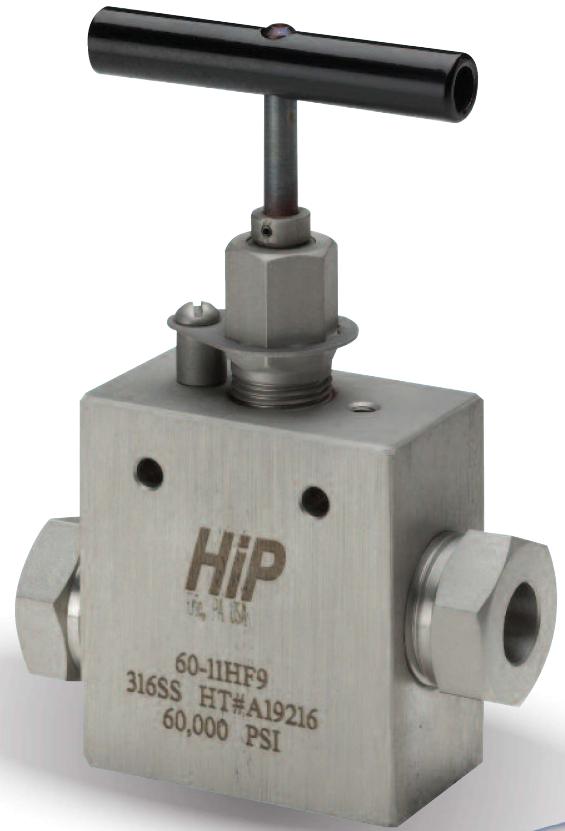

Markets

Our high standards for quality, service and value have enabled us to achieve preferred supplier status with a wide variety of market leaders in many different industries.

- **Waterjet Cutting and Blasting**
- **Oil and Gas**
- **Chemical and Petrochemical**
- **Research and Development**
- **Universities and Government**
- **General Industry**

ISO 9001
CERTIFIED

Valve Design

General

1

- Valve bodies through 100,000 psi are high tensile Type 316 stainless steel, 150,000 psi valve bodies are 17-4 PH stainless steel.
- Stem assemblies have non-rotating tips to prevent galling with valve seats.
- Packing is located below the stem threads to prevent contact with media (liquid or gas).
- Packing glands are equipped with locking devices or lock nuts.
- Six valve patterns (see chart on page 7).
- Tubing connections are: $\frac{1}{16}$ " , $\frac{1}{8}$ " , $\frac{1}{4}$ " , $\frac{3}{8}$ " , $\frac{9}{16}$ " , $\frac{3}{4}$ " , 1" and $1\frac{1}{2}$ ".
Pipe connections include: $\frac{1}{8}$ " , $\frac{1}{4}$ " , $\frac{3}{8}$ " , $\frac{1}{2}$ " , $\frac{3}{4}$ " , and 1" NPT.
- Remote control air operators are available for most valves.

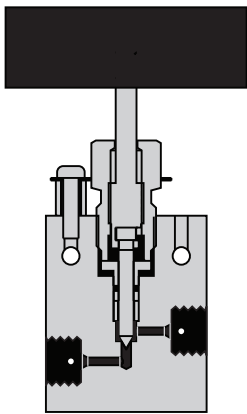

Slotted Stem

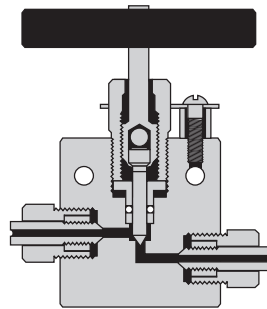

Rolled Style Stem

Slotted Stem: Non-rotating slotted stems are standard on AF4, AF6, LF4, LF6, LF9, HF6, HF4, and HF9 (30,000 psi) HF2, HF4, HF6, HF9 (60,000 psi) for on-off service and ensure long life on valve seats. Regulating tip stems are available for all valves at no additional cost, add -REG to part number.

Rolled Style Stem: This simple two-piece design is also non-rotating and is ideal for smaller valves and for valves made from exotic materials. The standard lower section stem is manufactured from hardened 17-4 PH stainless steel. It is affixed to a one-piece upper stem requiring no periodic adjustment. The two stem components are free to rotate independently of each other, thereby minimizing rotation of the lower stem against the valve seat.

The Rolled Style Stem is standard for all AF1, AF2, NFA, NFB, LF4, LF6 valves, 30,000 psi HF2, XF4, and XF6 valves, as well as most valves requiring stems made from exotic materials. It is optional for any valve normally supplied with a Positive Guide Stem.

Pinned Stem Design: This variation on the Rolled Style Stem is a three-piece design in which the lower stem is pinned into a freely-rotating stem guide. It has all of the advantages of the rolled style stem, with the additional benefit of a replaceable lower section stem.

The Pinned Stem Design is standard for all NFC, NFD, NFF, NFH, LF9, LF12, LF16, and HF16 valves.

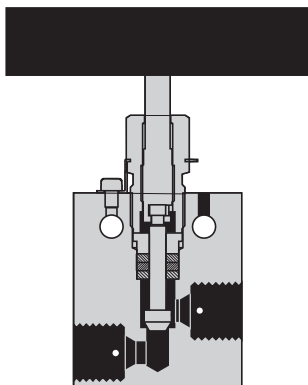

Pinned Stem

Quick Selector Guide to Standard Valves

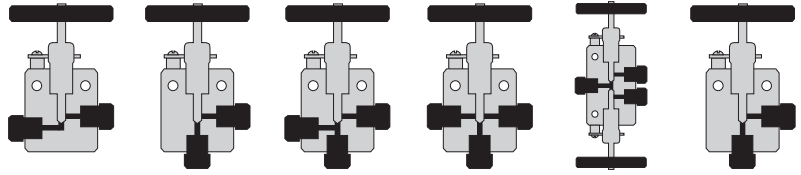

1

Taper Seal Valves

NPT Valves

Medium Pressure Valves

High Pressure Valves

Ultra High Pressure Valves

	10,000 psi	15,000 psi	10,000 psi	15,000 psi	10,000 psi	15,000 psi	20,000 psi	30,000 psi	60,000 psi	100,000 psi	150,000 psi	
	1/4" O.D. / 1/8" I.D.	1/8" O.D. / .030" I.D.	1/8" O.D. / 1/4" I.D.	1/8" O.D. / 1/16" I.D.	3/8" O.D. / 1/2" I.D.	1/2" O.D. / 3/4" I.D.	3/4" O.D. / 1" I.D.	1/4" O.D. / 7/64" I.D.	1/8" O.D. / .083" I.D.	1/8" O.D. / .020" I.D.	1/4" O.D. / 1/16" I.D.	3/8" O.D. / 1/16" I.D.
	Two Way Straight	Two Way Angle	Two Way Angle	Two Way Angle	Two Way Angle	Two Way Angle	Two Way Angle	Two Way Angle	Two Way Angle	Two Way Angle	Two Way Angle	Two Way Angle
	10-11AF4	10-12AF4	10-13AF4	10-14AF4	10-15AF4	10-12AF4-R	10-12AF6-R	15-11AF1	15-12AF1	15-13AF1	15-14AF1	15-15AF1
	10-11AF6	10-12AF6	10-13AF6	10-14AF6	10-15AF6	10-12AF6-R	10-12AF6-R	15-11AF2	15-12AF2	15-13AF2	15-14AF2	15-15AF2
	10-11NFA	10-12NFA	10-13NFA	10-14NFA	10-15NFA	10-12NFA-R	10-12NFA-R	10-11NFB	10-12NFB	10-13NFB	10-14NFB	10-15NFB
	10-11NFC	10-12NFC	10-13NFC	10-14NFC	10-15NFC	10-12NFC-R	10-12NFC-R	10-11NFD	10-12NFD	10-13NFD	10-14NFD	10-15NFD
	10F-11NFF	10F-12NFF	10F-13NFF	10F-14NFF	10F-15NFF	10F-12NFF-R	10F-12NFF-R	10F-11NFH	10F-12NFH	10F-13NFH	10F-14NFH	10F-15NFH
	10F-11NFH	10F-12NFH	10F-13NFH	10F-14NFH	10F-15NFH	10F-12NFH-R	10F-12NFH-R	15F-11NFA	15F-12NFA	15F-13NFA	15F-14NFA	15F-15NFA
	15F-11NFB	15F-12NFB	15F-13NFB	15F-14NFB	15F-15NFB	15F-12NFB-R	15F-12NFB-R	15F-11NFC	15F-12NFC	15F-13NFC	15F-14NFC	15F-15NFC
	15F-11NFD	15F-12NFD	15F-13NFD	15F-14NFD	15F-15NFD	15F-12NFC-R	15F-12NFC-R	15F-11NFD	15F-12NFD	15F-13NFD	15F-14NFD	15F-15NFD
	10-11LF12	10-12LF12	10-13LF12	10-14LF12	10-15LF12	10-12LF12-R	10-12LF12-R	1" 11/16"	10-11LF16	10-12LF16	10-13LF16	10-14LF16
	15-11LF24	15-12LF24	15-13LF24	15-14LF24	15-15LF24	15-12LF16-R	15-12LF16-R	1 1/2" 15/16"	15-11LF24	15-12LF24	15-13LF24	15-14LF24
	20-11LF4	20-12LF4	20-13LF4	20-14LF4	20-15LF4	20-12LF4R	20-12LF4R	20-11LF6	20-12LF6	20-13LF6	20-14LF6	20-15LF6
	20-11LF9	20-12LF9	20-13LF9	20-14LF9	20-15LF9	20-12LF6R	20-12LF6R	9/16" 5/16"	20-11LF9	20-12LF9	20-13LF9	20-14LF9
	20-11LF12	20-12LF12	20-13LF12	20-14LF12	20-15LF12	20-12LF9R	20-12LF9R	3/4" 33/64"	20-11LF12	20-12LF12	20-13LF12	20-14LF12
	20-11LF16	20-12LF16	20-13LF16	20-14LF16	20-15LF16	20-12LF12R	20-12LF12R	1" 11/16"	20-11LF16	20-12LF16	20-13LF16	20-14LF16
	30-11HF2	30-12HF2	30-13HF2	30-14HF2	30-15HF2	30-12HF2R	30-12HF2R	1/8" .040"	30-11HF2	30-12HF2	30-13HF2	30-14HF2
	30-11HF4	30-12HF4	30-13HF4	30-14HF4	30-15HF4	30-12HF4R	30-12HF4R	1/4" .083"	30-11HF4	30-12HF4	30-13HF4	30-14HF4
	30-11HF6	30-12HF6	30-13HF6	30-14HF6	30-15HF6	30-12HF6R	30-12HF6R	3/8" 1/8"	30-11HF6	30-12HF6	30-13HF6	30-14HF6
	30-11HF9	30-12HF9	30-13HF9	30-14HF9	30-15HF9	30-12HF9R	30-12HF9R	9/16" 3/16"	30-11HF9	30-12HF9	30-13HF9	30-14HF9
	30-11HF16	30-12HF16	30-13HF16	30-14HF16	30-15HF16	30-12HF9R	30-12HF9R	1" .437"	30-11HF16	30-12HF16	30-13HF16	30-14HF16
	60-11HF2	60-12HF2	60-13HF2	60-14HF2	60-15HF2	60-12HF2R	60-12HF2R	1/8" .020"	60-11HF2	60-12HF2	60-13HF2	60-14HF2
	60-11HF4	60-12HF4	60-13HF4	60-14HF4	60-15HF4	60-12HF4R	60-12HF4R	1/4" 1/16"	60-11HF4	60-12HF4	60-13HF4	60-14HF4
	60-11HF6	60-12HF6	60-13HF6	60-14HF6	60-15HF6	60-12HF6R	60-12HF6R	3/8" 1/8"	60-11HF6	60-12HF6	60-13HF6	60-14HF6
	60-11HF9	60-12HF9	60-13HF9	60-14HF9	60-15HF9	60-12HF6R	60-12HF6R	9/16" 3/16"	60-11HF9	60-12HF9	60-13HF9	60-14HF9
	100-11XF4	100-12XF4	100-13XF4	100-14XF4	NA	100-12XF4R	100-12XF4R	100,000 psi 1/4" 1/16"	100-11XF4	100-12XF4	100-13XF4	100-14XF4
	150-11XF6	150-12XF6	150-13XF6	150-14XF6	NA	150-12XF6R	150-12XF6R	150,000 psi 3/8" 1/16"	150-11XF6	150-12XF6	150-13XF6	150-14XF6

Catalog Numbering System

1

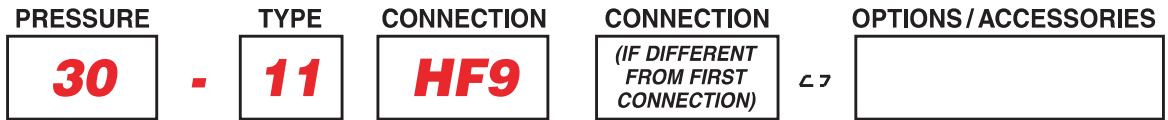

Pressure Series

- 10 = 10,000 psi
- 15 = 15,000 psi
- 20 = 20,000 psi
- 30 = 30,000 psi
- 40 = 40,000 psi
- 60 = 60,000 psi
- 100 = 100,000 psi
- 150 = 150,000 psi

Catalog part numbers for some components (NPT fittings, special alloy parts) have been maintained for historical consideration.

The referred pressure series may not reflect the actual pressure rating. Please refer to applicable catalog page for pressure rating, or consult the factory.

Type of Components

- 2 = Gland, Collar or Sleeve
- 3 = Anti-Vibration Assembly
- 7 = Plug
- 11 = 2-Way Straight Valve
- 12 = 2-Way Angle Valve
- 13 = 3-Way Valve with Two Pressure Connections
- 14 = 3-Way Valve with One Pressure Connections
- 15 = 3-Way, 2-Stem Valve
- 16 = Ball Valve (Floating)
- 21 = Coupling or Adapter
- 22 = Elbow
- 23 = Tee
- 24 = Cross
- 41 = Check Valve
- 51 = Line Filter
- 61 = Safety Head (Straight)
- 63 = Safety Head (Tee Type)
- 71 = 2-Way Ball Valve *
- 72 = 3-Way Ball Valve 180° *
- 73 = 3-Way Ball Valve Diverter *
- 74 = 2-Way Ball Valve *
- 75 = 3-Way Ball Valve 180° *
- 76 = 3-Way Ball Valve Diverter *
- 77 = 3-Way Mini Ball Valve 1/4" NPT
- 80 = 2-Way Ball Valve *
- 81 = 3-Way Ball Valve 180° *
- 82 = 3-Way Ball Valve Diverter *

* (Trunion)

Connection(s) Size and Type

Female	Male
AF1	AM1 1/16" Taper Seal
AF2	AM2 1/8" Taper Seal
AF4	AM4 1/4" Taper Seal
AF6	AM6 3/8" Taper Seal
LF4	LM4 1/4" Medium Pressure
LF6	LM6 3/8" Medium Pressure
LF9	LM9 9/16" Medium Pressure
LF12	LM12 3/4" Medium Pressure
LF16	LM16 1" Medium Pressure
LF24	LM24 1 1/2" Medium Pressure
HF2	HM2 1/8" High Pressure
HF4	HM4 1/4" High Pressure
HF6	HM6 3/8" High Pressure
HF9	HM9 9/16" High Pressure
HF16	HM16 1" High Pressure
XF4	XM4 1/4" Ultra High Pressure
XF6	XM6 3/8" Ultra High Pressure
NFA	NMA 1/8" NPT Pipe
NFB	NMB 1/4" NPT Pipe
NFC	NMC 3/8" NPT Pipe
NFD	NMD 1/2" NPT Pipe
NFF	NMF 3/4" NPT Pipe
NFH	NMH 1" NPT Pipe
—	HA9 9/16" Hose
—	HA12 3/4" Hose
—	HA16 1" Hose
—	HA21 1 5/16" Hose

Options

- V = Micro Control Metering Assembly
- HT = High Temperature Stem Extension (Up to 1,000° F)
- SGS = Sour Gas (H₂S) Service
- N/O = Normally Open
- N/C = Normally Closed
- K = With Antivibration Collars and Glands
- REG = Regulating Tip
- TSR8 = Ball Valve Actuator
- TDA8 = Ball Valve Actuator Double Acting
- W/O = Without Collars and Glands
- LT = Low Temperature Stem Extension (to -320°F)
- MPO-NO = Medium Duty Piston Operator Normally Open
- MPO-NC = Medium Duty Piston Operator Normally Closed
- HPO-NO = Heavy Duty Piston Operator Normally Open
- HPO-NC = Heavy Duty Piston Operator Normally Closed
- EHPO-NO = Extra Heavy Piston Operator Normally Open
- EHPO-NC = Extra Heavy Piston Operator Normally Closed
- OC = Oxygen Cleaning
- HL = Handle Lock (Ball Valve Only)
- MHNO = Mini Hippo Normally Open
- MHNC = Mini Hippo Normally Closed
- LS = Limit Switch

How to Order Valves and Fittings

Simply indicate catalog number and specify option or special requirement.

Examples:

30-11HF4 = 30,000 psi Straight Valve for 1/4" O.D. tubing

60-23HF4 = 60,000 psi Tee for 1/4" O.D. tubing

15-21AF2 = 15,000 psi Straight Coupling for 1/8" O.D. tubing, Taper Seal connections

15-21AF2NMB = 15,000 psi Adapter with one end 1/8" O.D. Female Taper Seal and opposite end Male 1/4" NPT Pipe

30-11HF6-HT = 30,000 psi Straight Valve for 3/8" O.D. tubing with High Temperature Extension

"HIPCO" 10-12NFB (N/C) = 10,000 psi Angle Valve for 1/4" NPT Pipe with "Hipco" Air Operator, Normally Closed

"HIPPO" 15-11A4F (N/C) = 10,000 psi Angle Valve for 1/4" Taper Seal with "Hippo" Piston Operator, Normally Closed

60-21HF4 (Hastelloy C-276) = 60,000 psi Straight Coupling for 1/4" O.D. tubing, made from Hastelloy C-276 material



High Pressure Equipment

Medium Pressure Valves, Fittings and Tubing 20,000 psi service

High Pressure Equipment Company has developed a line of Medium Pressure products to assure safe and easy plumbing through 20,000 psi. These needle valves, fittings, line filters, check valves, safety heads, rupture discs, anti-vibration gland assemblies, tubing and nipples are engineered to the highest standards of repeatable quality. The reliable performance of these products has made HiP one of the world's leading suppliers of elevated pressure components.

Medium Pressure components use a compact coned-and-threaded connection which permits the larger bore sizes and increased flow rates common in this pressure class. Medium Pressure valves are available in $\frac{1}{4}$ " , $\frac{3}{8}$ " , $\frac{9}{16}$ " , $\frac{3}{4}$ " , 1" and $1\frac{1}{2}$ " O.D. tubing sizes and six patterns to satisfy widely varied requirements. A line of fittings is available to facilitate adapting to Taper Seal, High Pressure or other threaded pipe systems.



Index

20,000 psi Valves*	29-30
Valve Options	31
Fittings	32
Unions, Bulkheads & Caps	33
Line Filters & Check Valves	34
Safety Heads	35
Rupture Discs	36
Anti-Vibration Gland Assemblies	37
Tubing	38
Coned & Threaded Nipples	38
Connection Details	39

*Note: 10,000 psi large orifice is offered in $\frac{3}{4}$ " and 1" size.



Medium Pressure (coned & threaded) type connections for $\frac{1}{4}$ ", $\frac{3}{8}$ ", $\frac{9}{16}$ ", $\frac{3}{4}$ ", 1" and $1\frac{1}{2}$ " O.D. tubing.

Non-rotating slotted stems are standard on LF4, LF6 and LF9 for on-off service and ensure long life on valve seats. Regulating tip stems are available for all valves at no additional cost, add - REG to part number.

Glands and collars for tubing are supplied with each valve unless otherwise requested (glands and collars shown on pages 32 and 39).

Materials include high tensile type 316 stainless steel bodies and hardened 17-4PH stainless steel lower section stems. $1\frac{1}{2}$ " O.D. valves are constructed of 2205 duplex.

Packing is Teflon (450°F) standard with optional Viton (350°F), BUNA-N (200°F) and Grafoil (800°F) available at no additional cost.

Air operators for remote control operation are available for all valves. (Refer to Air Operator section of catalog for additional data).

Extreme temperatures can be accommodated by using extended stuffing boxes (See Valve Options, page 31).

4

Valve Features

- Non-rotating slotted stem design (standard for LF4, LF6 and LF9)
- Packing below stem threads
- Positive gland lock device
- Tube sizes $\frac{1}{4}$ " through $1\frac{1}{2}$ "
- Type 316 ss high tensile bodies
- No stem adjustment needed – LF4, LF6 and LF9
- Black T-handles or choice of 4 colors – LF4, LF6 and LF9
- 316 ss handles LF12, LF16 and LF24

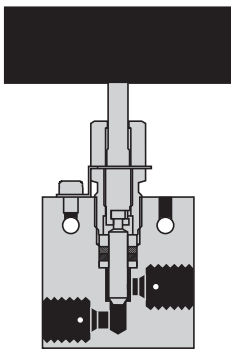

LF4 ($\frac{1}{4}$ ") and LF6 ($\frac{3}{8}$ ")

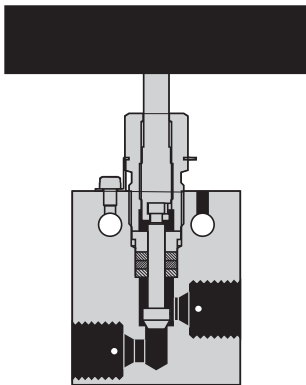

LF9 ($\frac{9}{16}$ ")

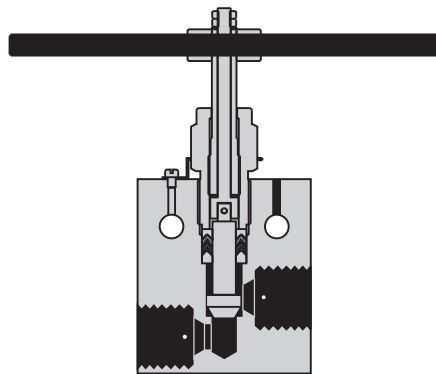

LF12 ($\frac{3}{4}$ ") and LF16 (1")*

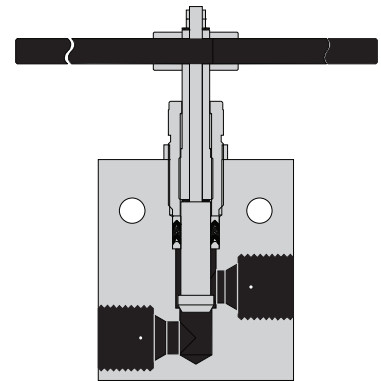

LF24 ($1\frac{1}{2}$ ") (Rated to 15,000 psi)

* Note: 10,000 psi large orifice is offered in $\frac{3}{4}$ " and 1" size.

Medium Pressure Valves

Two Way Straight Valves

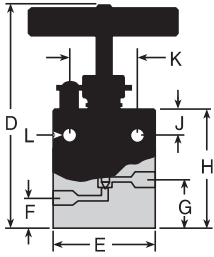

Tubing	Catalog No.	psi	Conn.	Orifice	Cv	D	E	F	G	H	J	K	L	Thickness
1/4" O.D.	20-11LF4	20,000	LF4	1/8"	0.17	4 ¹³ / ₁₆ "	2"	3/8"	1 ¹³ / ₁₆ "	2"	3/8"	1 1/4"	7/32"	3/4"
3/8" O.D.	20-11LF6	20,000	LF6	1 ³ / ₆₄ "	0.45	4 ³ / ₈ "	2"	3/8"	1 ¹³ / ₁₆ "	2"	3/8"	1 1/4"	7/32"	3/4"
9/16" O.D.	20-11LF9	20,000	LF9	5/16"	1.12	6 ⁷ / ₈ "	2 1/2"	1/2"	1 1/8"	2 7/8"	1/2"	1 3/8"	11/32"	1"
3/4" O.D.	20-11LF12	20,000	LF12	7/16"	2.29	7"	3"	3/4"	1 1/2"	3 3/4"	5/8"	1 3/4"	7/16"	1 3/8"
3/4" O.D.	10-11LF12	10,000	LF12	3 ³ / ₆₄ "	3.65	7"	3"	3/4"	1 1/2"	3 3/4"	5/8"	1 3/4"	7/16"	1 3/8"
1" O.D.	20-11LF16	20,000	LF16	9/16"	3.86	8 ²⁷ / ₆₄ "	4 1/8"	7/8"	1 13/16"	4 5/8"	1 1/8"	2 1/2"	9/16"	1 3/4"
1" O.D.	10-11LF16	10,000	LF16	1 1/16"	5.91	8 ²⁷ / ₆₄ "	4 1/8"	7/8"	1 13/16"	4 5/8"	1 1/8"	2 1/2"	9/16"	1 3/4"
1 1/2" O.D.	15-11LF24	15,000	LF24	1 ⁵ / ₁₆ "	-	9 ⁴⁵ / ₆₄ "	5 3/4"	1 1/4"	2 3/4"	6 1/2"	1 1/2"	3 3/4"	3/4"	2 1/4"

Two Way Angle Valves

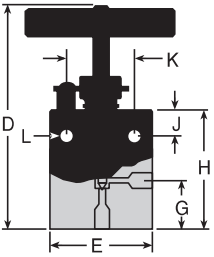

Tubing	Catalog No.	psi	Conn.	Orifice	Cv	D	E	F	G	H	J	K	L	Thickness
1/4" O.D.	20-12LF4	20,000	LF4	1/8"	0.255	4 ¹³ / ₁₆ "	2"	-	1 1/4"	2 7/16"	3/8"	1 1/4"	7/32"	3/4"
3/8" O.D.	20-12LF6	20,000	LF6	1 ³ / ₆₄ "	0.675	4 ¹³ / ₁₆ "	2"	-	1 1/4"	2 7/16"	3/8"	1 1/4"	7/32"	3/4"
9/16" O.D.	20-12LF9	20,000	LF9	5/16"	1.68	6 ⁵ / ₈ "	2 1/2"	-	1 5/8"	3 3/8"	1/2"	1 3/8"	11/32"	1"
3/4" O.D.	20-12LF12	20,000	LF12	7/16"	3.435	7 1/2"	3"	-	2"	4 1/4"	5/8"	1 3/4"	7/16"	1 3/8"
3/4" O.D.	10-12LF12	10,000	LF12	3 ³ / ₆₄ "	5.475	7 1/2"	3"	-	2"	4 1/4"	5/8"	1 3/4"	7/16"	1 3/8"
1" O.D.	20-12LF16	20,000	LF16	9/16"	5.79	9 ³ / ₈ "	4 1/8"	-	2 7/16"	5 7/16"	1 1/8"	2 1/2"	9/16"	1 3/4"
1" O.D.	10-12LF16	10,000	LF16	1 1/16"	8.865	9 ³ / ₈ "	4 1/8"	-	2 7/16"	5 7/16"	1 1/8"	2 1/2"	9/16"	1 3/4"
1 1/2" O.D.	15-12LF24	15,000	LF24	1 ⁵ / ₁₆ "	-	9 ⁶¹ / ₆₄ "	5 3/4"	-	3"	6 3/4"	1 1/2"	3 3/4"	3/4"	2 1/4"

Three Way Valves / Two Pressure Connections

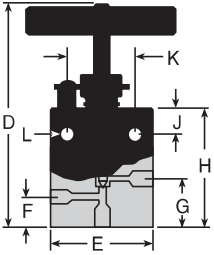

Tubing	Catalog No.	psi	Connection	Orifice	D	E	F	G	H	J	K	L	Thickness
1/4" O.D.	20-13LF4	20,000	LF4	1/8"	5"	2"	1"	1 7/16"	2 5/8"	3/8"	1 1/4"	7/32"	3/4"
3/8" O.D.	20-13LF6	20,000	LF6	1 ³ / ₆₄ "	5"	2"	1"	1 7/16"	2 5/8"	3/8"	1 1/4"	7/32"	3/4"
9/16" O.D.	20-13LF9	20,000	LF9	5/16"	6 7/8"	2 1/2"	1 1/4"	1 7/8"	3 5/8"	1/2"	1 3/8"	11/32"	1"
3/4" O.D.	20-13LF12	20,000	LF12	7/16"	7 7/8"	3"	2 5/8"	2 3/8"	4 5/8"	5/8"	1 3/4"	7/16"	1 3/8"
3/4" O.D.	10-13LF12	10,000	LF12	3 ³ / ₆₄ "	7 7/8"	3"	2 5/8"	2 3/8"	4 5/8"	5/8"	1 3/4"	7/16"	1 3/8"
1" O.D.	20-13LF16	20,000	LF16	9/16"	9 3/4"	4 1/8"	2 1/8"	3 1/16"	5 7/8"	1 1/8"	2 1/2"	9/16"	1 3/4"
1" O.D.	10-13LF16	10,000	LF16	1 1/16"	9 3/4"	4 1/8"	2 1/8"	3 1/16"	5 7/8"	1 1/8"	2 1/2"	9/16"	1 3/4"

Three Way Valves / One Pressure Connection

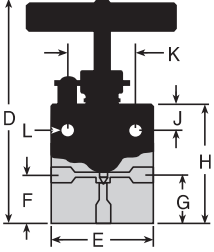

Tubing	Catalog No.	psi	Connection	Orifice	D	E	F	G	H	J	K	L	Thickness
1/4" O.D.	20-14LF4	20,000	LF4	1/8"	4 ¹³ / ₁₆ "	2"	1 1/4"	1 1/4"	2 7/16"	3/8"	1 1/4"	7/32"	3/4"
3/8" O.D.	20-14LF6	20,000	LF6	1 ³ / ₆₄ "	4 ¹³ / ₁₆ "	2"	1 1/4"	1 1/4"	2 7/16"	3/8"	1 1/4"	7/32"	3/4"
9/16" O.D.	20-14LF9	20,000	LF9	5/16"	6 ⁵ / ₈ "	2 1/2"	1 5/8"	1 5/8"	3 3/8"	1/2"	1 3/8"	11/32"	1"
3/4" O.D.	20-14LF12	20,000	LF12	7/16"	7 1/2"	3"	2"	2"	4 1/4"	5/8"	1 3/4"	7/16"	1 3/8"
3/4" O.D.	10-14LF12	10,000	LF12	3 ³ / ₆₄ "	7 1/2"	3"	2"	2"	4 1/4"	5/8"	1 3/4"	7/16"	1 3/8"
1" O.D.	20-14LF16	20,000	LF16	9/16"	9 ³ / ₈ "	4 1/8"	2 5/8"	2 5/8"	5 7/16"	1 1/8"	2 1/2"	9/16"	1 3/4"
1" O.D.	10-14LF16	10,000	LF16	1 1/16"	9 ³ / ₈ "	4 1/8"	2 5/8"	2 5/8"	5 7/16"	1 1/8"	2 1/2"	9/16"	1 3/4"

Three Way / Two Stem Connection Valves

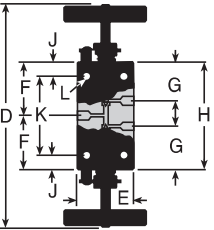

Tubing	Catalog No.	psi	Connection	Orifice	D	E	F	G	H	J	K	L	Thickness
1/4" O.D.	20-15LF4	20,000	LF4	1/8"	5 ³ / ₄ "	2"	1 11/16"	1 3/16"	3 3/8"	3/8"	1 1/4"	7/32"	3/4"
3/8" O.D.	20-15LF6	20,000	LF6	1 ³ / ₆₄ "	5 ³ / ₄ "	2"	1 11/16"	1 3/16"	3 3/8"	3/8"	1 1/4"	7/32"	3/4"
9/16" O.D.	20-15LF9	20,000	LF9	5/16"	8 ³ / ₈ "	2 1/2"	2 9/16"	1 3/4"	5 1/8"	1/2"	1 3/8"	11/32"	1"
3/4" O.D.	20-15LF12	20,000	LF12	7/16"	9 3/4"	3"	3 1/4"	2 1/4"	6 1/2"	5/8"	1 3/4"	7/16"	1 3/8"
3/4" O.D.	10-15LF12	10,000	LF12	3 ³ / ₆₄ "	9 3/4"	3"	3 1/4"	2 1/4"	6 1/2"	5/8"	1 3/4"	7/16"	1 3/8"
1" O.D.	20-15LF16	20,000	LF16	9/16"	12 ³ / ₁₆ "	4 1/8"	4 1/8"	2 3/16"	8 1/4"	1 1/8"	2 1/2"	9/16"	1 3/4"
1" O.D.	10-15LF16	10,000	LF16	1 1/16"	12 ³ / ₁₆ "	4 1/8"	4 1/8"	2 3/16"	8 1/4"	1 1/8"	2 1/2"	9/16"	1 3/4"

Replaceable Seat Valves

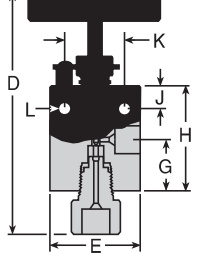

Tubing	Catalog No.	psi	Connection	Orifice	D	E	F	G	H	J	K	L	Thickness
1/4" O.D.	20-12LF4-R	20,000	LF4	1/8"	5 ⁵ / ₈ "	2"	-	1 1/4"	2 7/16"	3/8"	1 1/4"	7/32"	3/4"
3/8" O.D.	20-12LF6-R	20,000	LF6	1 ³ / ₆₄ "	5 ⁵ / ₈ "	2"	-	1 1/4"	2 7/16"	3/8"	1 1/4"	7/32"	3/4"
9/16" O.D.	20-12LF9-R	20,000	LF9	5/16"	8"	2 1/2"	-	1 5/8"	3 3/8"	1/2"	1 3/8"	11/32"	1"
3/4" O.D.	20-12LF12-R	20,000	LF12	7/16"	8 ⁷ / ₈ "	3"	-	2"	4 1/4"	5/8"	1 3/4"	7/16"	1 3/8"
3/4" O.D.	10-12LF12-R	10,000	LF12	3 ³ / ₆₄ "	8 ⁷ / ₈ "	3"	-	2"	4 1/4"	5/8"	1 3/4"	7/16"	1 3/8"
1" O.D.	20-12LF16-R	20,000	LF16	9/16"	11 1/8"	4 1/8"	-	2 7/16"	5 7/16"	1 1/8"	2 1/2"	9/16"	1 3/4"
1" O.D.	10-12LF16-R	10,000	LF16	1 1/16"	11 1/8"	4 1/8"	-	2 7/16"	5 7/16"	1 1/8"	2 1/2"	9/16"	1 3/4"

Valve Options

Extreme Temperature Valves

The Extreme Temperature Extension provides a means to move the packing area (stuffing box) away from the hot or cold zone of a valve. Fins are provided around the packing area to dissipate heat or cold with this option.

Size range. Extreme temperature extensions are available for all medium pressure valves.

Materials and features. Standard packing is Grafoil and Teflon. Nonrotating tip stems prevent galling at the seats and minimize torque requirements for positive shut off.

When ordering, simply add the suffix “-HT” or “-LT” to the standard valve catalog number (example: 20-11LF6-HT).

Temperature ratings of valves with this option, for low temperature (-LT) is -423°F (-252°C) and for high temperature (-HT) is 1200°F (649°C)

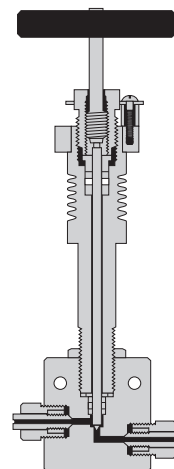

4

Micro Control Metering Valves

The Micro Control Metering Valve assembly is available for 1/16", 3/16" valves in this section. This unique stem design operates on the principle of a right-hand threaded component operating in an opposite direction of motion to a left-hand threaded component.

As the pitch sizes of these threads are different from each other, a very fine and precise stem travel is made possible. This provides exceptional control that is not possible with ordinary fine pitched stem designs.

Each complete revolution of the stem provides 0.005" stem travel. The vernier indicator allows readings in increments of one-tenth of a revolution (0.0005" stem travel).

The non-rotating lower section stem is ground to a 9 degree included angle to insure maximum control. **While this valve may be turned to the fully off (closed) position, it is always preferable to provide a separate on-off valve in the system to protect the precise control of the metering valve.**

When ordering, simply specify the valve catalog number from the valve series and add the suffix “-V” (example: 20-11LF4-V)

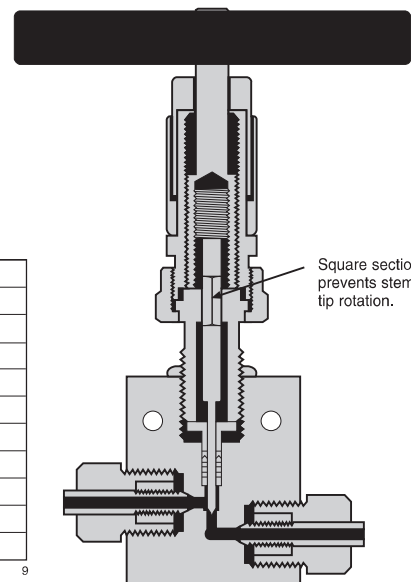
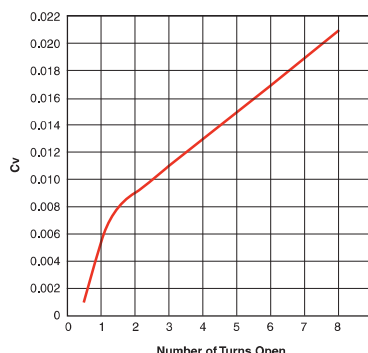

Special Materials

A large number of the valves and fittings shown within this catalog section are frequently furnished in special materials to meet the requirements of specific applications. One of the most commonly requested “special” materials is Hastelloy C-276.

Tubing collars and glands for High Pressure coned-and-threaded connections are “non-wetted” parts which do not normally come into contact with the fluid or gas. Thus these items are supplied in 316 stainless steel unless otherwise specified.

Packing material in all special material valves is Teflon unless otherwise specified.

Other materials. In addition to Hastelloy C-276, valves and fittings can be furnished in Monel, Inconel and titanium. Consult factory for price and delivery.

Packing Options

Medium Pressure

Material	Part Number			
	LF4/ LF6	LF9	LF12	LF16
Teflon*	B-1392 Set	207341 Set	208740 Set	208741 Set
Grafoil	B-1391 Set	B-1386 Set	B-1455 Set ¹	B-1440 Set ²
Polypak	B-1388 (1)	B-1387 (1)	B-1431 (1) ¹	B-1742 (1) ²

¹ LF12 Series: When Grafoil and Polypak are used, top washer 208937 and bottom washer 208939 must be installed



² LF16 Series: When Grafoil and Polypak are used, top washer 209308 and bottom washer 209309 must be installed

Medium Pressure Valves

Glands/Collars/Plugs/Elbows/Tees/Crosses

A complete range of elbows, tees, and crosses is available for all of the tubing connection sizes. Material is high tensile 316 stainless steel. Standard tubing glands and collars are provided unless otherwise specified.

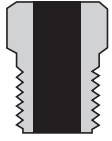
Connection Components

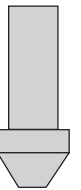
Catalog No.	Tube Size	Gland	Catalog No.	Tube Size	Collar	Catalog No.	Tube Size	Plug
20-2LM4	1/4"		20-2L4	1/4"		20-7LM4	1/4"	
20-2LM6	3/8"		20-2L6	3/8"		20-7LM6	3/8"	
20-2LM9	9/16"		20-2L9	9/16"		20-7LM9	9/16"	
20-2LM12	3/4"		20-2L12	3/4"		20-7LM12	3/4"	
20-2LM16	1"		20-2L16	1"		20-7LM16	1"	
15-2LM24	1 1/2"		15-2L24	1 1/2"		15-7LM24	1 1/2"	

Medium Pressure Elbows

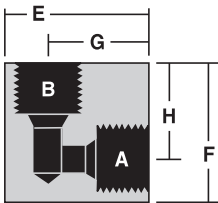

Catalog No.	Pressure Rating psi	Connections	A-B	E	F	G	H	Thickness
20-22LF4	20,000	1/4" O.D. TUBE	LF4	1 3/16"	1"	7/8"	1 1/16"	5/8"
20-22LF6	20,000	3/8" O.D. TUBE	LF6	1 3/8"	1 3/8"	1"	1"	3/4"
20-22LF9	20,000	9/16" O.D. TUBE	LF9	1 3/4"	1 3/4"	1 1/4"	1 1/4"	1"
20-22LF12	20,000	3/4" O.D. TUBE	LF12	2 1/4"	2 1/4"	1 1/2"	1 1/2"	1 3/8"
20-22LF16	20,000	1" O.D. TUBE	LF16	3"	3"	2 1/16"	2 1/16"	1 3/4"
15-22LF24	15,000	1 1/2" O.D. TUBE	LF24	5 3/4"	4"	2 7/8"	2 7/8"	2 1/4"

Medium Pressure Tees

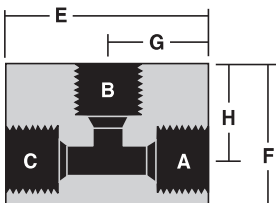

Catalog No.	Pressure Rating psi	Connections	A-B-C	E	F	G	H	Thickness
20-23LF4	20,000	1/4" O.D. TUBE	LF4	1 3/4"	1"	7/8"	1 1/16"	5/8"
20-23LF6	20,000	3/8" O.D. TUBE	LF6	2"	1 3/8"	1"	1"	3/4"
20-23LF9	20,000	9/16" O.D. TUBE	LF9	2 1/2"	1 3/4"	1 1/4"	1 1/4"	1"
20-23LF12	20,000	3/4" O.D. TUBE	LF12	3"	2 1/4"	1 1/2"	1 1/2"	1 3/8"
20-23LF16	20,000	1" O.D. TUBE	LF16	4 1/8"	3"	2 1/16"	2 1/16"	1 3/4"
15-23LF24	15,000	1 1/2" O.D. TUBE	LF24	5 3/4"	4"	2 7/8"	2 7/8"	2 1/4"

Medium Pressure Crosses

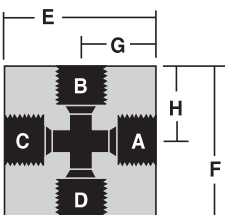

Catalog No.	Pressure Rating psi	Connections	A-B-C-D	E	F	G	H	Thickness
20-24LF4	20,000	1/4" O.D. TUBE	LF4	1 3/4"	1 3/8"	7/8"	1 1/16"	5/8"
20-24LF6	20,000	3/8" O.D. TUBE	LF6	2"	2"	1"	1"	3/4"
20-24LF9	20,000	9/16" O.D. TUBE	LF9	2 1/2"	2 1/2"	1 1/4"	1 1/4"	1"
20-24LF12	20,000	3/4" O.D. TUBE	LF12	3"	3"	1 1/2"	1 1/2"	1 3/8"
20-24LF16	20,000	1" O.D. TUBE	LF16	4 1/8"	4 1/8"	2 1/16"	2 1/16"	1 3/4"
15-24LF24	15,000	1 1/2" O.D. TUBE	LF24	5 3/4"	5 3/4"	2 7/8"	2 7/8"	2 1/4"

Union Couplings (Slip Type)

Union (slip type) couplings are ideal for use in confined space installations. This design allows the entire coupling to be disconnected and slipped back over the tubing to facilitate assembly and disassembly. In installations where tubing is easily assembled, it is preferable (and less expensive) to use standard straight couplings (see section 12). Standard material is high tensile 316 stainless steel. Standard tubing collars and glands are provided unless otherwise specified.

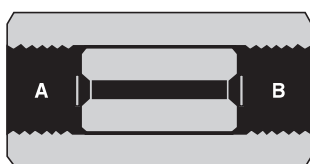

Catalog No.	Tubing	psi	A	B	Orifice	Length	Hex
20-21LF4-U	1/4" O.D.	20,000	LF4	LF4	1/8"	1 9/16"	5/8"
20-21LF6-U	3/8" O.D.	20,000	LF6	LF6	7/32"	1 3/4"	3/4"
20-21LF9-U	9/16" O.D.	20,000	LF9	LF9	23/64"	2 1/8"	1"
20-21LF12-U	3/4" O.D.	20,000	LF12	LF12	33/64"	2 1/2"	1 3/8"
20-21LF16-U	1" O.D.	20,000	LF16	LF16	1 1/16"	3 1/2"	1 3/4"
15-21LF24-U	1 1/2" O.D.	15,000	LF24	LF24	15/16"	5"	2 1/4"

4

Bulkhead Couplings

Bulkhead couplings are designed specifically for passing a tubing connection through a panel or steel barricade. These couplings include a locknut as shown. Material is high tensile 316 stainless steel. Standard tubing collars and glands are included unless otherwise specified.

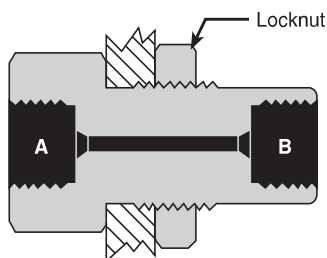

Catalog No.	Tubing	psi	Connections	Orifice	Length	Hex	Hole Diameter	Max. Panel Thickness
20-21LF4-B	1/4" O.D.	20,000	LF4	1/8"	1 7/8"	1"	13/16"	13/32"
20-21LF6-B	3/8" O.D.	20,000	LF6	7/32"	2"	1"	15/16"	7/16"
20-21LF9-B	9/16" O.D.	20,000	LF9	23/64"	2 3/8"	1 3/8"	1 1/8"	17/32"
20-21LF12-B	3/4" O.D.	20,000	LF12	33/64"	2 5/8"	1 7/8"	1 11/16"	3/8"
20-21LF16-B	1" O.D.	20,000	LF16	1 1/16"	3 1/2"	2 1/8"	1 15/16"	3/8"
15-21LF24-B	1 1/2" O.D.	15,000	LF24	15/16"	5"	2 1/2"	2 7/16"	1"

Caps

Tubing end caps are offered for use in sealing off tubing ends either for temporary use or permanent use, such as on small volume reservoirs. Standard material is high tensile 316 stainless steel. Standard tubing collars and glands are provided unless otherwise specified.

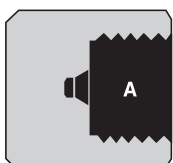

Catalog No.	Tubing	psi	A	Length	Hex
20-21LF4-C	1/4" O.D.	20,000	LF4	7/8"	5/8"
20-21LF6-C	3/8" O.D.	20,000	LF6	1 3/8"	3/4"
20-21LF9-C	9/16" O.D.	20,000	LF9	1 1/2"	1"
20-21LF12-C	3/4" O.D.	20,000	LF12	2 1/2"	1 3/8"
20-21LF16-C	1" O.D.	20,000	LF16	3"	1 3/4"
15-21LF24-C	1 1/2" O.D.	15,000	LF24	3 1/2"	2 1/4"

Medium Pressure Valves

Line Filters

The line filters as shown utilize sintered stainless steel filter discs 4 pc./set. Porosities are available as per the chart to the right. If not otherwise specified, 100 micron filter discs are supplied. (One micron = 0.001 millimeters). Material of body, caps and cover is high tensile 316 stainless steel. Standard tubing glands and collars are provided unless otherwise specified.

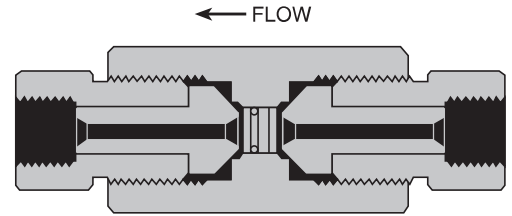

Catalog No.	Tubing	psi	Connections	Orifice	Length	Thickness	Micron Size Filter Available					
							0.5	2	5	10	40	100
20-51LF4	1/4" O.D.	20,000	LF4	1/8"	5 1/4"	1 3/8"	●	●	●	●	●	●
20-51LF6	3/8" O.D.	20,000	LF6	7/32"	5 1/4"	1 3/8"	●	●	●	●	●	●
20-51LF9	9/16" O.D.	20,000	LF9	23/64"	5 1/4"	1 3/8"	●	●	●	●	●	●

4

Ball Check Valves

Ball type check valves insure flow in one direction only. Material for body, caps and cover is high tensile 316 stainless steel. Standard tubing glands and collars are provided unless otherwise specified.

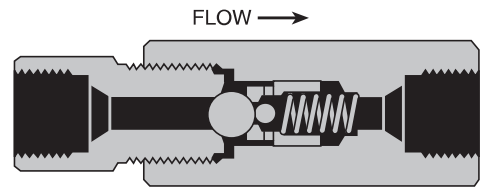

Catalog No.	Tubing	psi	Connections	Orifice	Length	Thickness
20-41LF4	1/4" O.D.	20,000	LF4	1/8"	3 3/4"	1"
20-41LF6	3/8" O.D.	20,000	LF6	7/32"	3 3/4"	1"
20-41LF9	9/16" O.D.	20,000	LF9	23/64"	4 1/2"	1 3/8"
20-41LF12	3/4" O.D.	20,000	LF12	7/16"	5 1/8"	1 3/4"
20-41LF16	1" O.D.	20,000	LF16	9/16"	6 1/2"	2 1/2"

Note: 20-41LF16 material 17-4PH

Soft Seat Check Valves

Soft seat check valves insure flow in one direction only and can be mounted in any position. These are highly reliable for both gas and liquid service. Standard material for the sealing surface (soft seat) is Buna-N (nitrile) on 1/4", 3/8" and 9/16" models, and Teflon on 3/4" and 1" models, with other materials (including each of these, as well as Viton) available upon request. Temperature is limited by the choice of O-ring material. Material of all other parts is high tensile 316 stainless steel. Standard glands and collars are provided unless otherwise specified.

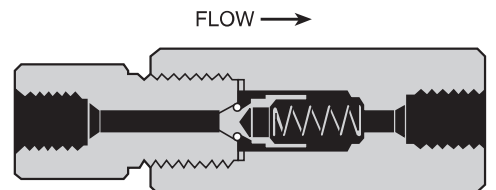

Catalog No.	Tubing	psi	Connections	Orifice	Length	Thickness
20-41LF4-T	1/4" O.D.	20,000	LF4	1/8"	3 3/4"	1"
20-41LF6-T	3/8" O.D.	20,000	LF6	7/32"	3 3/4"	1"
20-41LF9-T	9/16" O.D.	20,000	LF9	23/64"	4 1/2"	1 3/8"
20-41LF12-T	3/4" O.D.	20,000	LF12	7/16"	5 1/8"	1 3/4"
20-41LF16-T	1" O.D.	20,000	LF16	9/16"	6 1/2"	2 1/2"

Note: 20-41LF16 material 17-4PH

Safety Heads

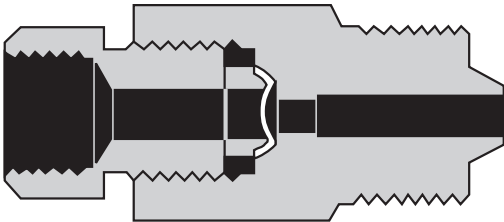

The male inlet design can be inserted directly into the tubing connections of valves and various fittings such as tees and crosses, or located in pressure vessels.

Outlet connections are $\frac{3}{8}$ " pipe (NPT). This outlet may be connected to a suitable discharge line to vent pressure to a safe location in the event of bursting of the rupture disc. Torque required for sealing rupture discs will range from 40 to 90 foot pounds, depending upon pressure and media being used.

Material of body and hold down nut is high tensile 316 stainless steel. Standard tubing glands and collars are provided unless otherwise specified.

Note: Rupture discs are **not** included and must be ordered as a separate item.

CE marked safety heads are now available, add -CE to end of standard part number. Consult factory for pricing.

4

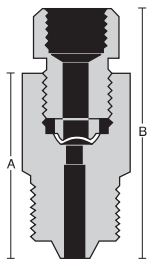

Male Inlet Safety Heads

Catalog No.	Pressure Rating psi	Inlet Connection	A	B	Hex Size
20-61LM4	20,000	$\frac{1}{4}$ " MEDIUM PRESSURE	2"	3"	1"
20-61LM6	20,000	$\frac{3}{8}$ " MEDIUM PRESSURE	2 $\frac{1}{8}$ "	3 $\frac{1}{8}$ "	1"
20-61LM9	20,000	$\frac{9}{16}$ " MEDIUM PRESSURE	2 $\frac{1}{4}$ "	3 $\frac{1}{4}$ "	1"
20-61LM12	20,000	$\frac{3}{4}$ " MEDIUM PRESSURE	2 $\frac{1}{2}$ "	3 $\frac{1}{2}$ "	1 $\frac{1}{4}$ "
20-61LM16	20,000	1" MEDIUM PRESSURE	3 $\frac{3}{8}$ "	4 $\frac{3}{8}$ "	1 $\frac{1}{8}$ "

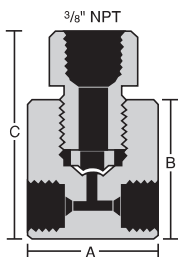

Tee Type Safety Heads

Catalog No.	Pressure Rating psi	Inlet Connection	A	B	Thickness
20-63LF4	20,000	$\frac{1}{4}$ " MEDIUM PRESSURE	1 $\frac{1}{2}$ "	1 $\frac{5}{8}$ "	2 $\frac{5}{8}$ "
20-63LF6	20,000	$\frac{3}{8}$ " MEDIUM PRESSURE	2"	1 $\frac{3}{4}$ "	2 $\frac{3}{4}$ "
20-63LF9	20,000	$\frac{9}{16}$ " MEDIUM PRESSURE	2 $\frac{1}{2}$ "	2"	3"

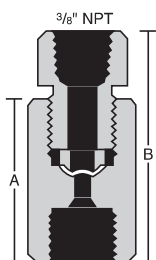

Female Inlet (Straight) Safety Heads

Catalog No.	Pressure Rating psi	Inlet Connection	A	B	Hex Size
20-61LF4	20,000	$\frac{1}{4}$ " MEDIUM PRESSURE	1 $\frac{7}{8}$ "	2 $\frac{7}{8}$ "	1"
20-61LF6	20,000	$\frac{3}{8}$ " MEDIUM PRESSURE	2"	3"	1"
20-61LF9	20,000	$\frac{1}{2}$ " MEDIUM PRESSURE	2 $\frac{1}{4}$ "	3 $\frac{1}{4}$ "	1"

Medium Pressure Valves

Rupture Discs 1/4" Angled Seat

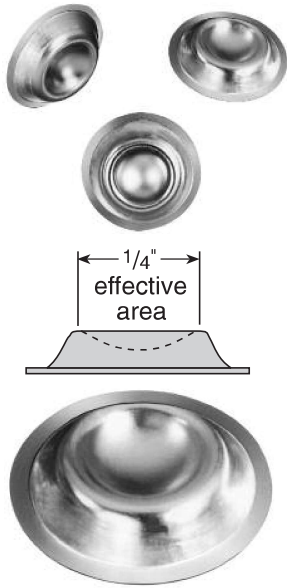

SPECIAL DISCS are available on special order for pressure ranges not shown below and in numerous materials and coatings. Consult factory for price and delivery.

Standard rupture discs are available from stock in burst pressures as listed in the chart below. All pressures through 20,000 psi are shaded. These discs are 316 stainless steel (except for 1,000 psi which are inconel) and may be used with any of the safety heads shown. Note that these rupture discs are supplied with a range of plus 6% and minus 3% of specified burst pressure. Samples of each batch are then tested and typically the actual average burst pressure is stamped on an accompanying metal tag. There is a +/- 5% burst tolerance applied after the burst pressure has been established. Factors influencing rupture disc life include corrosion, metal fatigue, and cyclic effects. Periodic replacement is recommended to prevent premature failure.

Standard Burst Pressures (in psi at 72°F)

1,000	3,000	5,000	7,000	9,000	11,000	17,500	25,000	37,500	55,000
1,500	3,500	5,500	7,500	9,500	11,500	18,000	27,000	40,000	60,000
2,000	4,000	6,000	8,000	10,000	12,500	20,000	30,000	45,000	65,000
2,500	4,500	6,500	8,500	10,500	15,000	22,500	35,000	50,000	

Anti-Vibration Gland Assemblies

Tubing systems that are subject to extreme vibration or shock, such as mobile pressure systems or long tubing runs culminating at a compressor, will benefit from the use of High Pressure Equipment Company's Anti-Vibration Gland Assemblies. These assemblies utilize the same reliable connection geometries as the standard HiP fittings, with the added benefit of essentially unlimited vibrational fatigue life.

A coned and threaded tube, when subjected to unusual or excessive vibration, may fail prematurely and break at the last thread. The Anti-Vibration Gland Assembly acts to move the fulcrum of vibration away from the threaded portion of the tube and onto the strong, solid wall of the tubing. A wedge-like collet firmly holds the assembly in place, virtually eliminating premature tubing failure while reliably maintaining a leak-free connection between the tube and the connection seat.

4

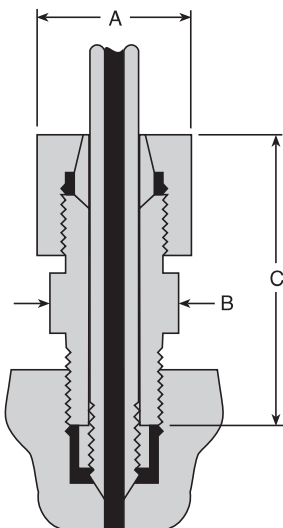

Medium Pressure Anti-Vibration Gland Assemblies

Catalog No.	Pressure Rating psi	Connections	A	B	C
20-3LM4	20,000	1/4" MEDIUM PRESSURE	5/8"	1/2"	1 7/16"
20-3LM6	20,000	3/8" MEDIUM PRESSURE	3/4"	5/8"	1 5/8"
20-3LM9	20,000	9/16" MEDIUM PRESSURE	1"	7/8"	1 7/8"
20-3LM12	20,000	3/4" MEDIUM PRESSURE	1 1/4"	1 1/8"	2 1/8"
20-3LM16	20,000	1" MEDIUM PRESSURE	1 1/2"	1 3/8"	2 1/2"

Anti-Vibration Components

Tubing Size	Slotted Collet	Collet Gland	Collet Body	Collar
1/4"	2-8769	2-8770	2-8768	20-2L4
3/8"	2-8772	2-8773	2-8771	20-2L6
9/16"	2-8775	2-8776	2-8774	20-2L9
3/4"	2-8778	2-8779	2-8777	20-2L12
1"	2-8781	2-8782	2-8780	20-2L16

Medium Pressure Valves

Medium Pressure Tubing

Tubing is cold drawn, seamless, and is supplied in the $\frac{1}{8}$ hard condition (not annealed). Tensile strength is approximately 40 percent higher than that of annealed tubing. All tubing is manufactured in strict accordance with High Pressure Equipment Company specifications to insure tolerances and bore quality. Tubing is stocked in lengths of 20 to 24 feet but may be ordered in shorter lengths with **no additional cutting charge**.

4

	Tubing Size	Working Pressure psi	Wall Thickness	Type of Connection Used	Material	Catalog Order Number
1/4"	1/4" O.D. x 0.109" I.D.	20,000	0.070"	1/4" MEDIUM PRESSURE (LF4)	316 SS	20-9M4-316
3/8"	3/8" O.D. x 0.203" I.D.	20,000	0.086"	3/8" MEDIUM PRESSURE (LF6)	316 SS	20-9M6-316
9/16"	9/16" O.D. x 0.359" I.D.	15,000	0.100"	9/16" MEDIUM PRESSURE (LF9)	316 SS	10-9M9-316
	9/16" O.D. x 0.312" I.D.	20,000	0.124"		304 SS	20-9M9-304
					316 SS	20-9M9-316
3/4"	3/4" O.D. x 0.516" I.D.	15,000	0.117"	3/4" MEDIUM PRESSURE (LF12)	316 SS	10-9M12-316
	3/4" O.D. x 0.438" I.D.	20,000	0.156"			20-9M12-316
1"	1" O.D. x 0.688" I.D.	15,000	0.156"	1" MEDIUM PRESSURE (LF16)	316 SS	10-9M16-316
	1" O.D. x 0.562" I.D.	20,000	0.219"			20-9M16-316
1 1/2"	1 1/2" O.D. x 0.937" I.D.	15,000	0.281"	1 1/2" MEDIUM PRESSURE (LF24)	316 SS	15-9M24-316

Nipples

Nipples are stocked in 316 stainless steel. Nipples in lengths other than those shown are supplied upon request. Nipples are not furnished with collars and glands, unless specified at time of order.

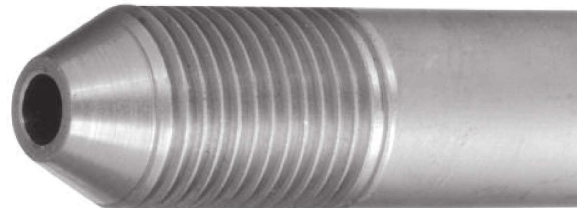

Coned and Threaded Nipples

Length ↓	Tubing Size (O.D. x I.D.)							
	1/2" O.D. x 7/64" I.D.	3/8" O.D. x 13/64" I.D.	9/16" O.D. x 5/16" I.D.	3/4" O.D. x 33/64" I.D.	3/4" O.D. x 7/16" I.D.	1" O.D. x 11/16" I.D.	1" O.D. x 9/16" I.D.	1 1/2" O.D. x 15/16" I.D.
psi →	20,000 psi	20,000 psi	20,000 psi	10,000 psi	20,000 psi	10,000 psi	20,000 psi	15,000 psi
2 3/4"	20-LM4-2.75							
3"		20-LM6-3						
4"			20-LM9-4	10-LM12-4				
6"	20-LM4-6	20-LM6-6	20-LM9-6	10-LM12-6	20-LM12-6	10-LM16-6	20-LM16-6	15-LM24-6
8"	20-LM4-8	20-LM6-8	20-LM9-8	10-LM12-8	20-LM12-8	10-LM16-8	20-LM16-8	15-LM24-8
10"	20-LM4-10	20-LM6-10	20-LM9-10	10-LM12-10	20-LM12-10	10-LM16-10	20-LM16-10	15-LM24-10
12"	20-LM4-12	20-LM6-12	20-LM9-12	10-LM12-12	20-LM12-12	10-LM16-12	20-LM16-12	15-LM24-12

Medium Pressure Connections

The Medium Pressure tubing connection is available for $\frac{1}{4}$ ", $\frac{3}{8}$ ", $\frac{9}{16}$ " $\frac{3}{4}$ ", and 1" O.D. tubing. The tubing may be prepared with the use of tooling (see Tooling section 15) or prepared at the factory to specified lengths. Additionally, standard length coned and threaded nipples are available from stock (see page 38).

This connection has become an industry standard for use at elevated pressures and temperatures in both liquid and gas applications. It may be disassembled and retightened indefinitely. The threads of the gland are right-hand while the threads of the collar and tubing are left-hand to prevent rotation of the collar during assembly.

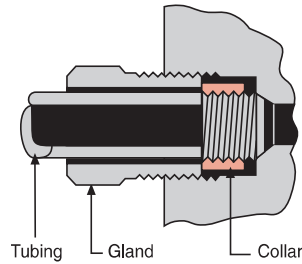

Materials. All of the components required for make-up of a Medium Pressure connection (glands, collars and plugs) are produced in Type 316 stainless steel.

Glands and collars. All valves and fittings are provided (except nipples) unless otherwise requested. (See chart on the right for size details and catalog numbers).

4

20,000 psi					
LF4 1/4" O.D. Tubing	LF6 3/8" O.D. Tubing	LF9 9/16" O.D. Tubing	LF12 3/4" O.D. Tubing	LF16 1" O.D. Tubing	LF24 1 1/2" O.D. Tubing
Female Opening Detail					
Gland					
Collar					
Plug					
Tube End Prep					